



3512B Land Electric-Drive Drilling Module

1045 kW (1492 kVA)
1101 bkW (1476 bhp)
60 Hz (1200 rpm)

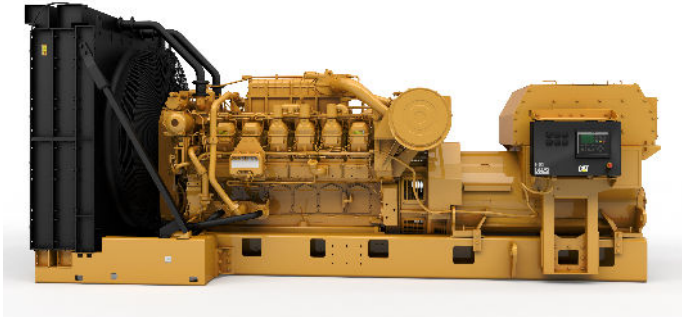

Image shown with optional attachments.

CAT® MODULE SPECIFICATIONS

V-12, 4-Stroke-Cycle-Diesel

Emissions	Non-certified
Bore	170 mm (6.69 in)
Stroke	190 mm (7.48 in)
Displacement	52 L (3158 in ³)
Aspiration	Turbocharged-Aftercooled
Fuel System	EUI
Engine Control and Protection	ADEM™ A3
Generator	SR500
Voltage	600
Instrumentation	EMCP 4.3

Note: Power rating does not include radiator fan power.

FEATURES

Product Design

- Developed specifically to meet the demands of oil and gas applications
- Latest electronics for enhanced safety, performance, and user interface
- Proven reliability and durability
- Robust base design for high durability and ideal for loading/unloading operations
- Market-leading power density
- Rugged, oversized cooling system for 50°C ambient capability at rated power
- Long overhaul life proven in oilfield applications
- Core engine components designed for reconditioning and reuse at overhaul

Ease of Installation

- Inner-outer base mounting configuration simplifies rig integration
- Wide range of attachments enable configuration flexibility
- Inner base three-point generator mounting maintains factory alignment
- Single lifting point simplifies installation work

Safety

- E-stop pushbutton on instrument panel
- Air shutoff and explosion relief valves available
- Configurable alarm, derate, and shutdown set points
- Extra alarms, inputs, and outputs available

Custom Packaging

For any petroleum application, trust Caterpillar to meet your exact needs with a factory custom package. Cat engines, generators, enclosures, controls, radiators,

transmissions — anything your project requires — can be custom-designed and matched to meet any project requirement. Custom packages are globally supported and are covered by a one-year warranty after startup.

Testing

- Every Cat module is full-load tested to ensure proper engine performance.
- Standard configurations are assembled, tested, and validated as a package to ensure performance, reliability and durability.

Product Support Offered Through Global Cat Dealer Network

- More than 2,200 dealer outlets
- Cat factory-trained dealer technicians service every aspect of your Cat petroleum product
- Worldwide parts availability, service, and warranty
- Preventive maintenance agreements available for repair-before-failure options
- S•O•SSM program matches your oil and coolant samples against Caterpillar set standards to determine:
 - Internal engine component condition
 - Presence of unwanted fluids
 - Presence of combustion by-products
 - Site-specific oil change interval

Over 80 Years of Engine Manufacturing Experience

Ownership of these manufacturing processes enables Caterpillar to produce high quality, dependable products.

Web Site

For all your petroleum power requirements, visit www.cat.com/oilandgas.

CONFIGURATION

Air Inlet System

Corrosion-resistant aftercooler core

Air inlet shutoff

Air cleaner options:

- *Regular duty
- Heavy duty

+ Remote air inlet adapter – rectangular

+ Remote air inlet adapter – round

Control System

ADEM A3 ECU, left-hand mounted

Engine control options:

- *Direct rack control 0-200 mADC, space heater and jacket water heater connection and controls
- Cat DVR control, includes reactive droop capability, 3-phase voltage sensing, kVAR/PF modes, RFI suppression, min/max exciter limiter and exciter diode monitor, space heater and jacket water heater connection and controls
- Direct rack control 0-200 mADC with 6 stator RTDs, 2 bearing RTDs, space heater and jacket water heater connection and controls
- Cat DVR control, includes reactive droop capability, 3-phase voltage sensing, kVAR/PF modes, RFI suppression, min/max exciter limiter and exciter diode monitor, space heater and jacket water heater connection and controls, 6 stator RTDs, 2 bearing RTDs

+ Load sharing governor, 2301A

Cooling System

Separate-circuit aftercooled

Outlet controlled jacket water thermostat

Jacket water pump – gear driven

Dual outlet

Aftercooler water pump – gear driven

Aftercooler water thermostat

Radiator options:

- *Caterpillar supplied radiator, 46/CVS-stacked 0.627 ratio, includes blower fan, fan drive, pulley, belt guard, coolant level sensor, regulator, and fuel cooler
- Remote cooling connection RH
- Remote cooling connection LH
- Customer-provided radiator
- Custom radiator

Cooling system connection options (for use with customer-supplied radiator):

- Dual outlet coupling type connections
- Dual outlet hose and clamp type connections

Fan drive and belt guard (for use with remote and customer-supplied radiators)

Fan pulley options (for use with customer-supplied radiator):

- Front stub shaft
- Front stub shaft, 0.627 ratio pulley
- Front stub shaft, 0.605 ratio pulley
- Front stub shaft with 197 mm pulley
- Front stub shaft with 248 mm pulley
- Custom

+ Coolant level sensor

+ Blower fan, 1829 mm (for use with customer-supplied radiator)

Exhaust System

Dry exhaust manifold

Dual turbochargers, water cooled bearings

Exhaust expander options:

- 203 mm to 310 mm (8 in to 12 in)
- *No exhaust expander included

Flexible exhaust fitting options:

- Flexible fitting, 203 mm (8 in) ID
- *No flexible fitting included

+ Elbow, 305 mm (12 in)

+ Muffler, 305 mm (12 in)

+ Muffler, 356 mm (14 in) – spark arresting, includes companion flanges, clean-out box, and spark box

+ Muffler, 305 mm (12 in) – spark arresting, includes companion flanges, clean-out box, and spark box

Flywheel and Housing

SAE No. 00 flywheel

SAE No. 00 flywheel housing

SAE standard rotation

Fuel System

Fuel transfer pump

Fuel return line with flexible connection

Electronic unit injectors

Fuel filter options:

- *Fuel filter simplex (LH) with priming pump (LH)
- Custom fuel filter

+ Primary fuel filter

+ Primary fuel filter with water separator

Generator Attachments

Generator terminal box options:

- Barrel-mounted petroleum terminal box
- Barrel-mounted petroleum terminal box with air filter and pressure differential switch

+ Current transformers (3)

+ Cable access box

Instrumentation

Emergency stop button

Analog gauges:

- Fuel pressure
- Engine oil pressure
- Engine oil temperature
- Engine coolant temperature
- DC voltage
- Engine percent load

EMCP 4.3 control panel

- 5.5 inch graphical display
- 16 languages supported
- Engine/generator monitoring and protection
- CAN, RS 485 MODBUS, Ethernet communications supported
- Remote e-stop/start/stop
- Engine start and crank attempt counter

Thermocouple options:

- Thermocouples installed, one per cylinder
- *No thermocouples included

Service port connector

*Denotes which option is included in the standard configuration

+ Optional attachment

CONFIGURATION (continued)

Customer connection terminal blocks
 + Communications module PL1000T
 + Communications module PL1000E

Lubrication System

Crankcase breather
 Oil cooler
 Shallow oil pan
 Oil drain extension, 2 in NPT female connection
 Oil filter options:
 – *Simplex oil filter
 – Custom oil filter
 Centrifugal oil filter options:
 – RH installed centrifugal oil filter
 – *No centrifugal oil filter included
 Lubricating oil options:
 – SAE15W40, Caterpillar DEO, 500 hour
 – *No lubricating oil included
 + Crankcase fumes disposal
 + Oil level regulator

Mounting System

Inner base options:
 – *4.19 m (165 in) length, 412 mm (16.2 in) height tubes,
 1.18 m (50.5 in) wide
 – Custom base
 Outer base options:
 – *No outer base included
 – Custom outer base
 + Package isolator supports (3) – for mounting inner base
 to customer-supplied base

Power Take-off

Charging alternator options
 – *No alternator
 – Alternator, 24V, 68A

Protection System

Alarms:
 – ECU voltage
 – Oil pressure
 – Low/high water temperature
 – Overspeed

– Crankcase pressure
 – Aftercooler temperature
 – Low water level (optional)
 – Air inlet restriction
 – Exhaust stack temperature
 – Oil/fuel filter differential pressure

Derate:

– High water temperature
 – Crankcase pressure
 – Aftercooler temperature
 – Air inlet restriction
 – Exhaust temperature

Shutdown:

– Oil pressure
 – Low/high water temperature
 – Overspeed
 – Crankcase pressure
 – Aftercooler temperature

Explosion relief valve options:

– Explosion relief valves (3)
 – *No explosion relief valves

+ Metal particle detector switch
 + Metal particle detector with annunciator

Starting System
Starting motor options:

– *TDI air starting motor, RH – 1034 kPa (150 psi)
 – Custom starting motor

+ Air pressure regulator

General
Barring group options:

– LH installed engine barring group
 – *No barring group included

Jacket water heater options:

– Jacket water heater, UL recognized, 120-240V, single
 phase, 6 kW, LH and RH mounted
 – Jacket water heater, UL recognized, 120-480V, single
 phase, 12 kW, LH and RH mounted
 – *No jacket water heater included

+ Jacket water heater lines

*Denotes which option is included in the standard configuration

+ Optional attachment



TECHNICAL DATA

3512B Land Electric-Drive Drilling Module – 1200 rpm

	Units	DM6522
Module Data		
Rated power without fan	ekW	1045
kVA rating	kVA	1492
Rated power factor		0.7
Frequency	Hz	60
Engine Data		
Engine power	bkW (bhp)	1101 (1476)
Engine speed	rpm	1200
Max. altitude without derate	m (ft)	2450 (8038)
BMEP	kPa (psi)	2127 (308)
BSFC @ 100% load	g/bkW-hr (lb/bhp-hr)	208 (0.34)
BSFC @ 75% load	g/bkW-hr (lb/bhp-hr)	207 (0.34)
BSFC @ 50% load	g/bkW-hr (lb/bhp-hr)	210 (0.35)
BSFC @ 25% load	g/bkW-hr (lb/bhp-hr)	229 (0.38)
Fuel consumption (nominal)	L/hr (gal/hr)	272.8 (72.1)
Air flow rate (@25°C, 101.3 kPa)	m ³ /min (ft ³ /min)	89.4 (3157)
Inlet manifold pressure	kPa (psi)	266 (38.6)
Inlet manifold temperature	°C (°F)	71.9 (161.4)
Aftercooler water temperature	°C (°F)	60 (140)
Jacket water temperature	°C (°F)	99 (210)
Exhaust stack temperature	°C (°F)	413.3 (776)
Exhaust flow rate (@ stack temp, 101.3 kPa)	m ³ /min (ft ³ /min)	216.1 (7631)
Lube oil system capacity	L (gal)	318 (84)
Engine coolant capacity	L (gal)	157 (41)
Radiator coolant capacity (JW)	L (gal)	284 (75)
Radiator coolant capacity (AC)	L (gal)	197 (52)
Oil change interval	Hours	500
Generator Data		
Frame size		500
Efficiency		95%
Voltage	Volts	600
Design kVA rating	kVA	1673
Insulation class		H
Temperature rise (@ 40°C ambient temp)	°C	80
Coastal protection		Included
Excitation		PM or SE
Number of poles		6
Winding		Form wound
Pitch		0 8
Number of leads		6
Number of bearings		2
Ingress protection (IP) rating		23
Alignment		Close coupled
Space heater	W	1200
RTDs per phase		2
RTD resistance	Ohm	10

ALTITUDE AND AMBIENT DERATION FACTORS

	10°C	20°C	30°C	40°C	50°C
0 m	1.00	1.00	1.00	1.00	1.00
300 m	1.00	1.00	1.00	1.00	1.00
500 m	1.00	1.00	1.00	1.00	1.00
1000 m	1.00	1.00	1.00	1.00	1.00
1500 m	1.00	1.00	1.00	1.00	1.00
2000 m	1.00	1.00	1.00	0.97	0.94
2500 m	1.00	0.98	0.94	0.91	0.88
3000 m	0.95	0.92	0.89	0.86	0.83
3200 m	0.92	0.89	0.86	0.84	0.81

EMCP 4.3 FEATURES
140 mm (5.5 in) Graphical Display

- Generator AC voltage
- 3-phase (L-L & L-N)
- $\pm 0.25\%$ accuracy
- rpm and battery voltage
- Generator AC current (per phase and average)
- Generator frequency
- Power metering (kW, kVA, kVA_r, pf)
- Hour meters (kW-hour, kVA_r-hour)
- Engine oil pressure (psi, kPa or bar)
- Engine oil temperature (°C or °F)
- Engine coolant temperature (°C or °F)
- Multiple language support
- Engine start and crank attempt counter
- Real time clock

Communication

- Accessory CAN data link
- RS-485 annunciator data link
- RS-485 SCADA (Modbus RTU)
- Ethernet SCADA (Modbus TCP)

Controls

- Auto/start/stop
- Engine cooldown timer
- Emergency stop
- Engine cycle crank
- Programmable cycle timer

Protection

- Over/under voltage
- Over/under frequency
- Generator phase sequence
- Over current (timed and inverse)
- Reverse kW, kVA
- Current balance
- Low oil pressure
- High coolant temp
- Low coolant level
- Fail to start
- Overspeed

Outputs

- 16 programmable digital outputs
- 3 programmable (4-20mA or $\pm 10V$)
- 2 programmable (PWM)

Inputs

- Emergency stop
- Remote start
- 12 programmable digital inputs
- Oil pressure and water temperature
- 3 programmable inputs ($\pm 10V$, PWM, current, or resistive)
- Oil temperature, fuel level

Other Features

- 16 languages supported:
 - Arabic
 - Chinese
 - Danish
 - Dutch
 - English
 - Finnish
 - French
 - German
 - Greek
 - Italian
 - Japanese
 - Portuguese
 - Russian
 - Spanish
 - Swedish
 - Turkish
- Programmable security levels
- Reduced power mode
- Programmable kW relay
- Cat switchgear integration
- Status event log



LAND ELECTRIC-DRIVE DRILLING MODULE

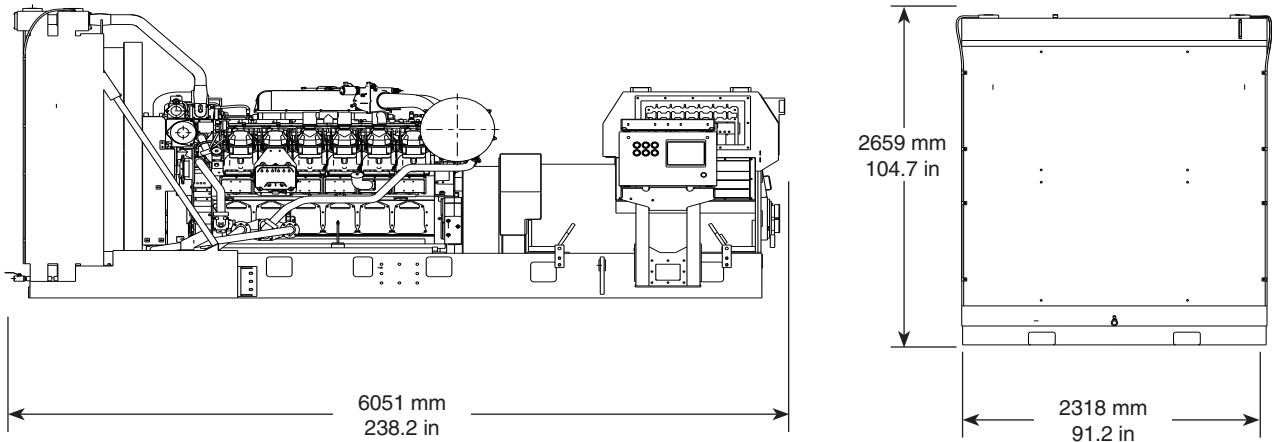

Dimensions and Weight		
Length	6051 mm	238.2 in
Width	2318 mm	91.2 in
Height	2659 mm	104.7 in
Weight	14 140 kg	31,108 lb

*Module weight is dry and includes engine, generator, and base.

Note: Do not use for installation design. See installation drawing for details.

RATING DEFINITIONS AND CONDITIONS

Prime Rating – Output available with varying load for an unlimited time. Prime power in accordance with ISO8528. Typical load factor 60-70%

Conditions – Performance is obtained and corrected in accordance with ISO 3046/1. Reference atmospheric inlet air: 100 kPa (29.61 in Hg), 25°C (77°F), 30% relative humidity at stated aftercooler temperature. Performance is also in accordance with SAE J1995, BS5514/1, and DIN6271/1 standard reference conditions

Diesel Fuel – Reference fuel is #2 distillate diesel with a 35 degree API gravity, lower heating value is 42 780 kJ/kg (18,390 Btu/lb) when used at 29°C (84.2°F), where the density is 838.9 g/L (7.001 lb/gal).

Information contained in this publication may be considered confidential. Discretion is recommended when distributing. Materials and specifications are subject to change without notice. The International System of Units (SI) is used in this publication. CAT, CATERPILLAR, their respective logos, ADEM, S•O•S, "Caterpillar Yellow" and the "Power Edge" trade dress, as well as corporate and product identity used herein, are trademarks of Caterpillar and may not be used without permission.